



MHOTPWR

Proven Performance

K-BAR Industries, Faribault, MN, 55021

ITEM NUMBER: 157321,322,325,326

SERIAL NUMBER: _____

HP: _____ Volts: _____ Amp: _____ Ph: _____

RPM: _____ PSI: _____ GPM: _____ Nozzle Size: _____

Pump: _____ Hose: _____ Lance: _____

Max. Discharge Temperature: _____

Installation, Operation, and Maintenance Manual

HOT WATER PRESSURE WASHER: *Cleans dirty surfaces with high pressure hot water.*

To the Owner:

Thank you for purchasing a Northstar hot water pressure washer. Your machine is designed for long life, dependability, and the top performance you demand! Take time now to read through this manual so you better understand the machine's operation, maintenance and safety precautions. Everyone who operates this machine must read and understand this manual. The time you take now will prolong your machine's life and prepare you for its safe operation. Enjoy the exceptional performance of your Northstar hot water pressure washer, the industry leader! The manufacturer reserves the right to make improvements in design and/or changes in specifications at any time without incurring any obligation to install them on units previously sold.

Quick Facts

Pump Oil	Pump is shipped with oil. Change oil plug and check pump oil level before starting. Use SAE 30 Non-detergent pump oil (item# 4043) or Cat Pump oil (item# 22158) for oil changes.	
Water	Make sure your water flow is 20% higher than the pressure washer's flow rate. Make sure your water is clean and particle free.	
Storage	Do not allow water to freeze in the pump, hose, coil, or spray gun.	
Spraying Chemicals	Use any North Star brand or equivalent pressure washer chemicals. Adjust soap adjustment knob to regulate cleaning power.	
Maintenance Schedule	Pump:	Oil: change after first 50 hours, then every 3 months or 500 hours.

Read and understand all manuals before operating.

Any Questions, Comments, Problems or Parts Orders

<p>In the United States Northstar Customer Service Call 1-800-270-0810 Hours: Monday - Friday 7:00 AM to 5:30 PM Saturday 7:30 AM-11:30 AM Central Time</p>	<p>In the United Kingdom Call 02392639752 Northern Tool and Equipment Co. (UK) Ltd. Unit 2, Keel Close, Portsmouth, Hants PO3 5QD, England</p>
---	--

Table of Contents			
Important Safety Instructions	2	Safety Features	12
Grounding Instructions	3	Maintenance Instructions	13-16
Extension Cords	3	Moving and Handling Instructions	17
Specifications	4	Long Term Storage	17
Machine Component Identification	5	Troubleshooting	18-19
Installation Instructions	6-9	Parts Breakdowns	20-26
Operation Instructions	10-12	Wiring Diagram	27-28

Important Safety Instructions

WARNING -Risk of Injection or Injury to Persons - Do Not Direct Discharge Stream at Persons. - Do not use a hose if exterior damage is evident.

-Risk of explosion. - Do not spray flammable liquids. - Do not operate in a flammable environment.

CAUTION -Risk of Asphyxiation - Exhaust fumes are deadly, for outdoor use only. Avoid inhaling exhaust fumes.

-Risk of fire. Do not add fuel when the product is operating or hot.

-Gun kicks back. Hold with both hands.

-To reduce the risk of injury, read operating instructions carefully before use.

WARNING - When using this product basic precautions should always be followed, including the following:

- 1.) Read all the instructions before using the product.
- 2.) To reduce the risk of injury, close supervision is necessary when the product is used near children. Do not allow irresponsible use by children. Always stop the product and bleed pressures before leaving unattended, disconnecting hoses, or servicing the pump.
- 3.) Know how to stop the product and bleed pressures quickly. Be thoroughly familiar with the controls.
- 4.) Stay alert - watch what you are doing.
- 5.) Do not operate the product when fatigued or under the influence of alcohol or drugs. Never smoke while operating or fueling this machine.
- 6.) Keep operating area clear of all persons.
- 7.) Do not overreach or stand on unstable support. Keep good footing and balance at all times. Wear footwear capable of maintaining a good grip on wet surfaces - Do not place the machine on soft or unstable ground.
- 8.) Follow the maintenance instructions specified in all manuals. Do not run machine without sufficient lubrication or sufficient water to cool the pump.
- 9.) Wear safety glasses, gloves, face protection and appropriate clothing when operating the machine.
- 10.) Do not operate this machine with broken or missing parts. - Never alter the manufacturer's original design or deactivate any safety device on the machine.
- 11.) Risk of exposure to dangerous chemicals. Wear protective gloves when handling and cleaning with chemicals. Follow the chemical manufacturer's directions. Understand all safety hazards and first aid for all chemicals being used. Check whether dangerous chemicals have been used and take any precautions that may have been recommended by the supplier of these chemicals when cleaning filters. Do not pump highly abrasive fluids or use with incompatible chemicals or solvents.
- 12.) Know the pressure and temperature limits of your machine. Be sure all high pressure accessories meet or exceed your machine's limits. Do not set the pressure relief valve above the machine's limit.
- 13.) Do not move this machine by pulling on the hose. Do not use the pump to support other items of equipment that impose unacceptable loads on the pump. Do not attempt to use this machine as a prop.
- 14.) To reduce risk of injury, do not secure the spray gun open. Your spray gun is equipped with a built-in trigger safety latch to guard against accidental trigger release and potentially dangerous high pressure spray. Rotate the safety latch to the locked position when not spraying.
- 15.) Do not clean this machine with its own spray. Cleaning should be done with a damp sponge with the motor OFF.
- 16.) NEVER attempt to immediately run or re-light the burner if it doesn't ignite the first time. Unburned oil or gas may have accumulated causing potential explosion or fire hazard.
- 17.) Always make sure all switches and controls are in the OFF position prior to plugging in the electrical cord. Do not stand in water while plugging and unplugging electrical cord.
- 18.) This product is provided with a ground fault circuit interrupter built into the power cord plug. If replacement of the plug or cord is needed, use only identical replacement parts.

SAVE THESE INSTRUCTIONS

Grounding Instructions

This product must be grounded. If it should malfunction or breakdown, grounding provides a path of least resistance for electric current to reduce the risk of electrical shock. This product is equipped with a cord having an equipment-grounding conductor and a grounding plug. The plug must be plugged into an appropriate outlet that is properly installed and grounded in accordance with all local codes and ordinances.

DANGER - Improper connection of the equipment - grounding conductor can result in a risk of electrocution. Check with a qualified electrician or service personnel if you are in doubt as to whether the outlet is properly grounded. Do not modify the plug provided with the product - if it will not fit the outlet, have a proper outlet installed by a qualified electrician. Do not use any type adapter with this product.

1. For a product rated 125 volts or less:

GROUND FAULT CIRCUIT INTERRUPTER PROTECTION

This pressure washer is provided with a ground fault circuit interrupter (GFCI) built into the plug of the power supply cord. This device provides additional protection from the risk of electric shock. Should replacement of the plug or cord become necessary, use only identical replacement parts that include GFCI protection.

2. For a product rated more than 125 volts:

GROUND FAULT CIRCUIT INTERRUPTER PROTECTION

To comply with the National Electric Code (NFPA 70) and to provide additional protection from the risk of electric shock, this pressure washer should only be connected to a receptacle that is protected by a ground fault circuit interrupter (GFCI).

Extension Cords

Use only 3-wire extension cords that have 3 prong grounding-type plugs and 3-pole cord connectors that accept the plug from the product. Use only extension cords that are intended for outdoor use. These extension cords are identified by a marking "Acceptable for use with outdoor appliances; store indoors while not in use." Use only extension cords having an electrical rating not less than the rating of the product. Do not abuse extension cord and do not yank on any cord to disconnect. Keep cord away from heat and sharp edges. Always disconnect the extension cord from the receptacle before disconnecting the product from the extension cord.

Warning - To reduce the risk of electrocution, keep all connections dry and off the ground. do not touch plug with wet hands.

SAVE THESE INSTRUCTIONS

Specifications

	Item Number			
	157321	157322	157325	157326
Pressure Rating	1000 psi	1000 psi	2000 psi	2000 psi
Flow Output	2 gpm	2 gpm	3.5 gpm	3.5 gpm
Pump Type	Ceramic Triplex Plunger	Ceramic Triplex Plunger	Ceramic Triplex Plunger	Ceramic Triplex Plunger
Water Supply	Standard tap water @ 20-100psi	Standard tap water @ 20-100psi	Standard tap water @ 20-100psi	Standard tap water @ 20-100psi
Motor Horsepower	1.5 hp	1.5 hp	5 hp	5 hp
BTU Output	221,400 BTU	221,400 BTU	270,000 BTU	270,000 BTU
Temperature Rise	140 F	140°F - (190°F steam mode)	140°F	140°F - (190°F steam mode)
Maximum Temperature	210°F	250°F	210°F	250°F
Approved Fuels	#1 or 2 Diesel, Kerosene, Fuel Oil	#1 or 2 Diesel, Kerosene, Fuel Oil	#1 or 2 Diesel, Kerosene, Fuel Oil	#1 or 2 Diesel, Kerosene, Fuel Oil
Fuel Capacity	8.25 gal.	8.25 gal.	8.25 gal.	8.25 gal.
Discharge Hose	3/8" x 30'	3/8" x 50'	3/8" x 30'	3/8" x 50'
Power Requirements				
NEMA Receptacles	5-20R	5-20R	6-30R	6-30R
Volts	115V	115V	230V	230V
Amps	20A	20A	30A	30A
Hertz	60Hz	60Hz	60Hz	60Hz
Phase	single	single	single	single
Dimensions				
Length	38"	38"	38"	38"
Width	26"	26"	26"	26"
Height	43"	43"	43"	43"
Ship Weight	355 lb.	360 lb.	420 lb.	415 lb.

Machine Component Identification

157321, 157322, 157325, 157326

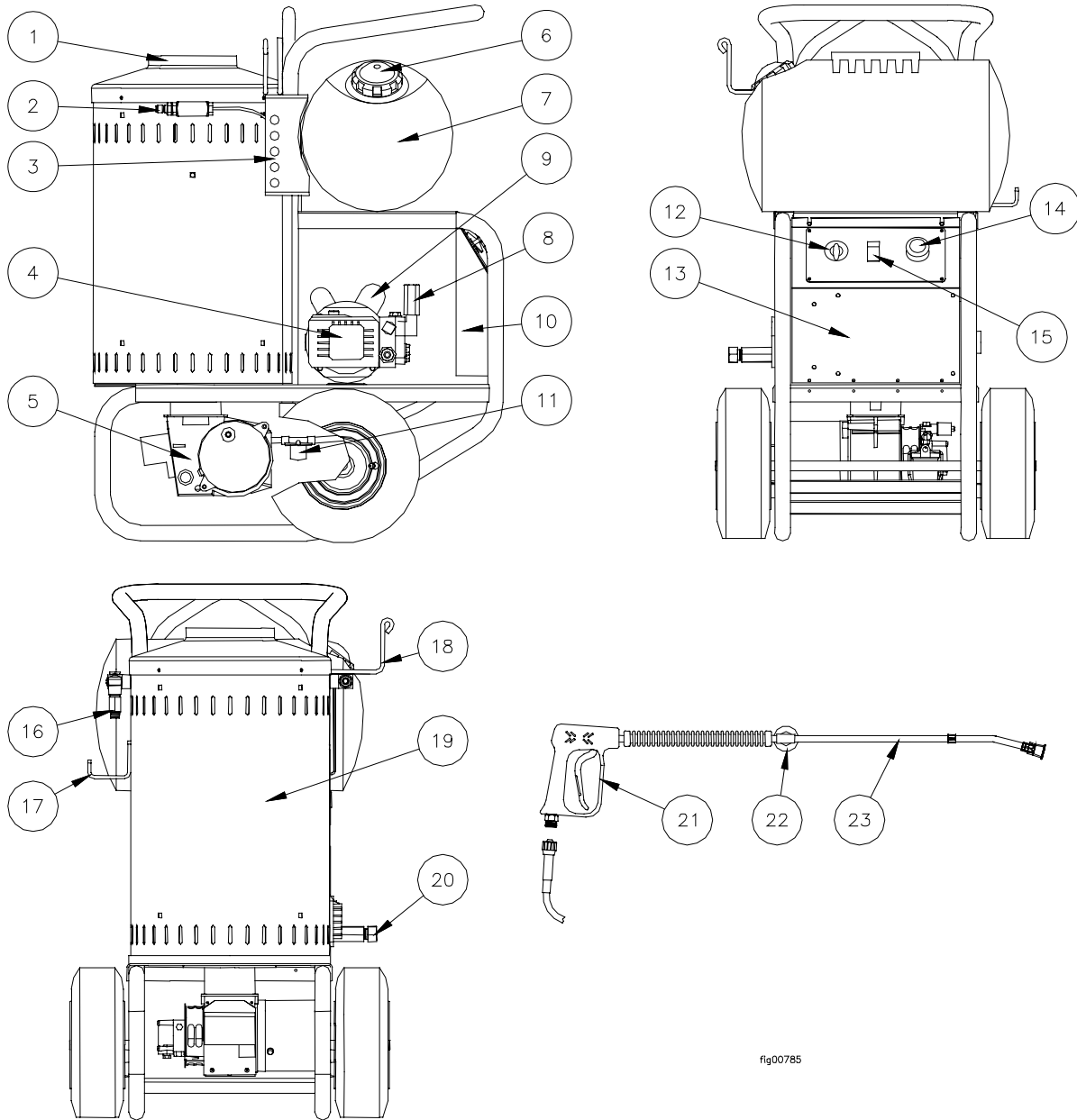

fig00785

Ref #	Description	Ref #	Description	Ref #	Description
1	Exhaust Vent	10	Control Box	19	Heating Coil
2	High Pressure Water Outlet	11	Fuel Filter	20	Garden Hose Water Inlet
3	Nozzle Holders	12	Main Power Switch	21	Spray Gun
4	Pump	13	Service Panel	22	Grip
5	Burner	14	Thermostat (optional)	23	Dual Lance Wand
6	Fuel Fill Cap	15	Heat Switch		
7	Fuel Tank	16	Safety Relief Valve		
8	Unloader	17	Power Cord Hanger		
9	Motor	18	Wand Holder		

Installation Instructions

I.) Unpack

Separate and identify all components. Use the assembly instructions in this manual for assembly.



Hex Wrench
Qty-1

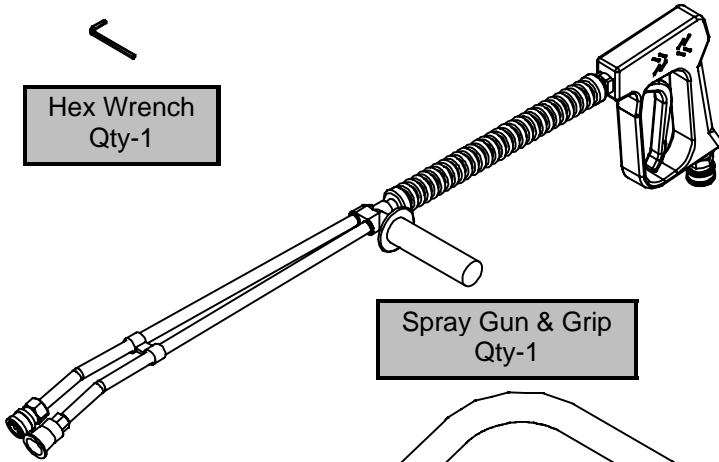

Spray Gun & Grip
Qty-1

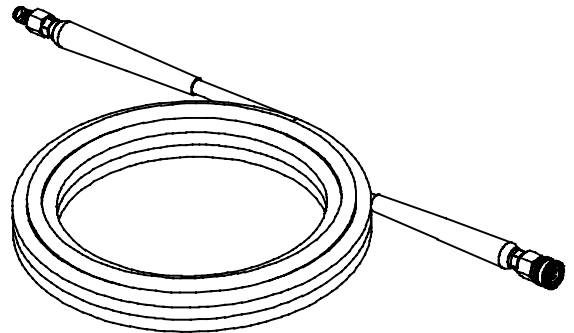

High Pressure Hose
Qty-1

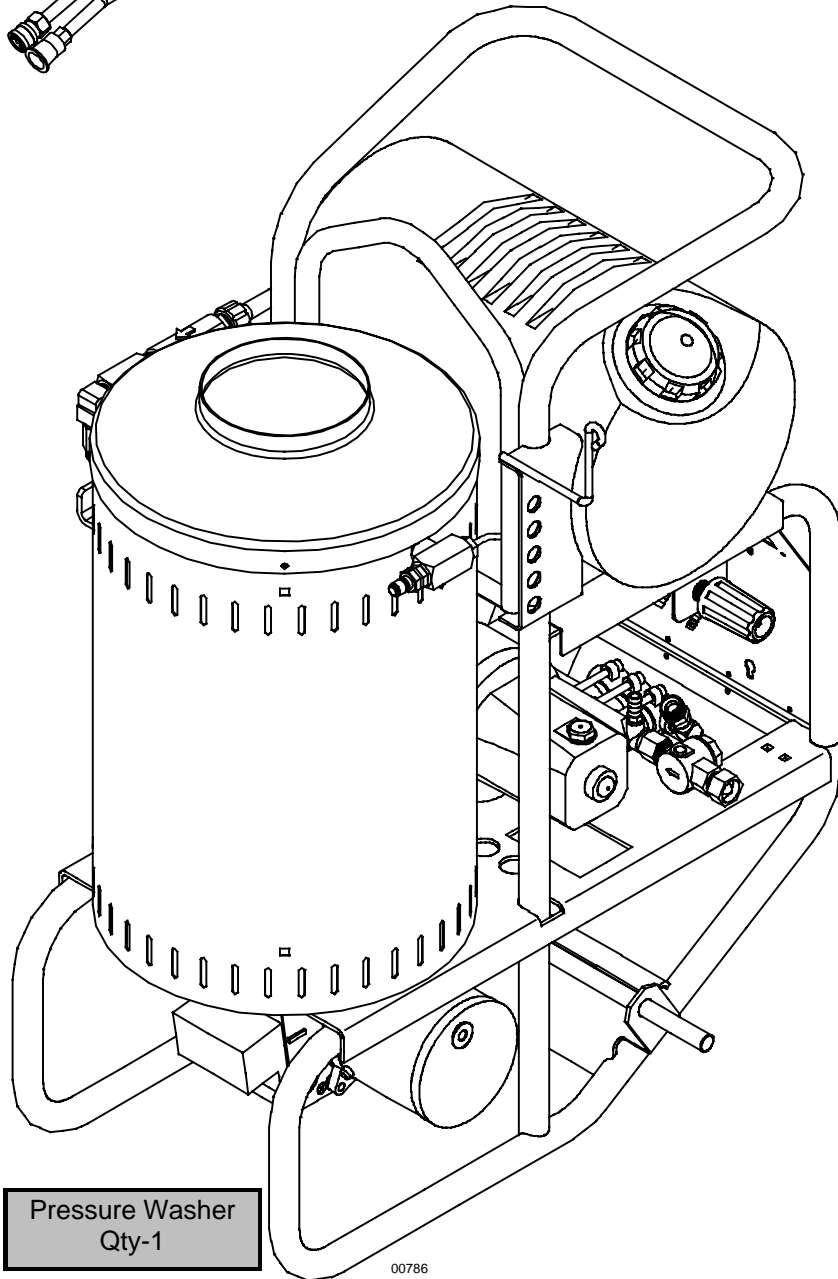

Pressure Washer
Qty-1

00786



Fastener Bag
Qty-1



Wheel Retainer
Qty-2

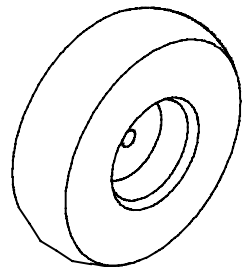

Wheel
Qty-2



Nozzle
157321, 157325 Qty-4
157322, 157326 Qty-5

II.) Assembly Instructions

- A. 1. Carefully raise the pressure washer off the floor by using blocks or ramps. Make sure the pressure washer is secure before proceeding.
 2. Install the two wheels as shown with grease zerk away from frame.
 3. Slide the two wheel retainers onto the end of the axle. Tighten the set screw with the hex wrench provided in the parts bag .

Description	Qty.
Wheel	2
Wheel Retainer	2

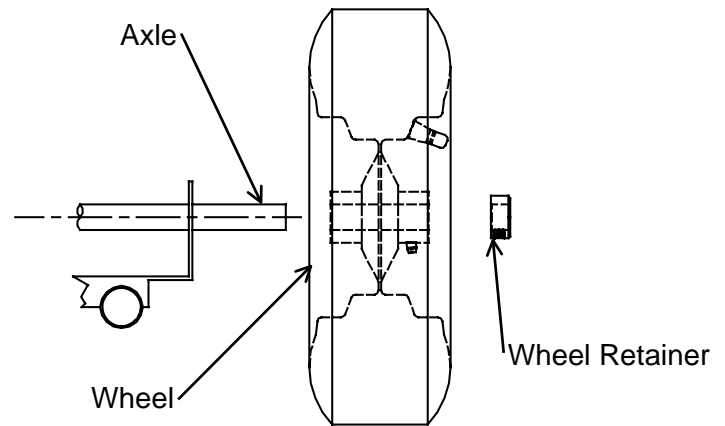

- B. 1. Install the pressure hose onto the pressure washer as shown.
 2. Connect the other end of the pressure hose to the spray gun as shown.
 3. Make sure all plumbing connections are tight.

Description	Qty.
Spray Gun/ Lance	1
Spray Hose	1

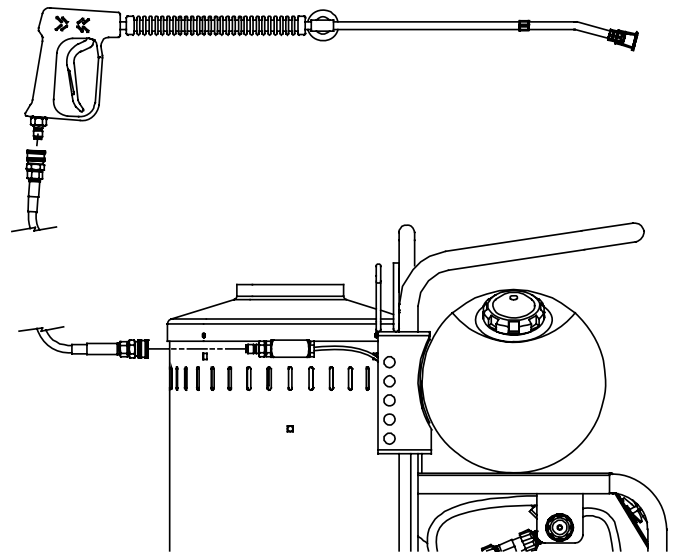

00787

III.) Pump Preparation

***AR Pumps Only**

- A.) Remove the shipping plug from the oil fill hole.
- B.) Screw the vented dipstick into oil fill hole.
- C.) Check oil level in the pump. Make sure it is 1/2 way up the sight glass .

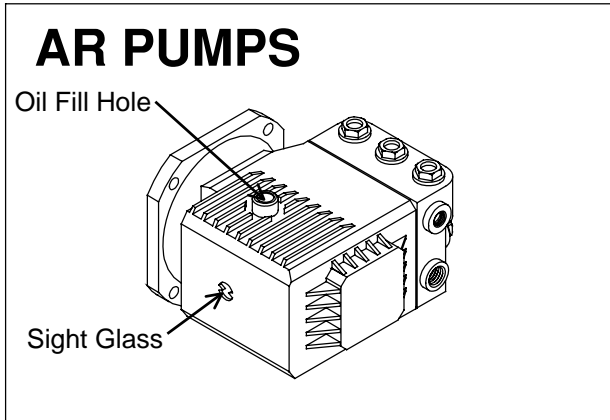

****Cat Pumps Only**

- A.) Remove shipping tape from oil fill cap
- B.) Make sure the oil is 1/2 way up oil sight glass.

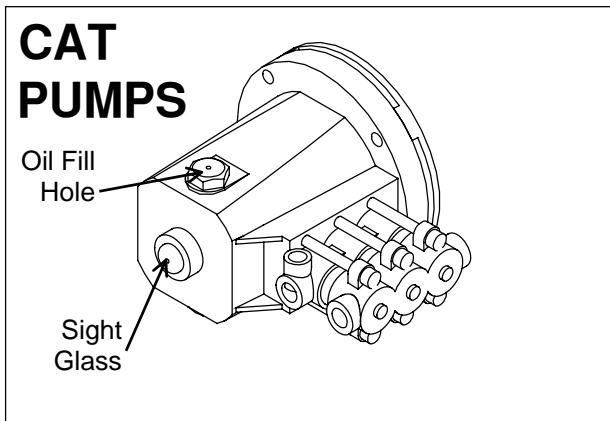

Quantities Of Fluid

Pump	Type of Fluid	QTY
AR XTV	SAE 30*	8.0oz (0.24L)
AR XMV	SAE 30*	14.0oz (0.41L)
Cat 2SFX	SAE 30**	11.83oz (0.35L)

*SAE Non-Detergent Oil (order Pump Oil Item# 4043)

**SAE Non-Detergent (order Cat Pump Oil Item# 22158)

IV.) Chemical Injector Preparation

- A.) Push clear hose onto chemical strainer.
- B.) Push other end of clear hose onto chemical injector

V.) Getting Started

IMPORTANT: Proper initial installation of equipment will assure more satisfactory performance, longer service life, and lower maintenance cost.

IMPORTANT: The use of a back flow preventer (Part #222815 call 1-800-270-0810 to order) on the water supply hose is recommended and may be required by local code.

Make sure the pressure washer is on a level surface and in a protected area where it is not readily influenced by outside forces such as strong winds, freezing temperatures, rain, etc. Locate the pressure washer for easy access for filling fluids, adjustments, and maintenance.

It is recommended that a partition be made between the wash area and the pressure washer to prevent direct nozzle spray from coming in contact with the pressure washer. Moisture reaching the equipment will reduce the pressure washer's service life.

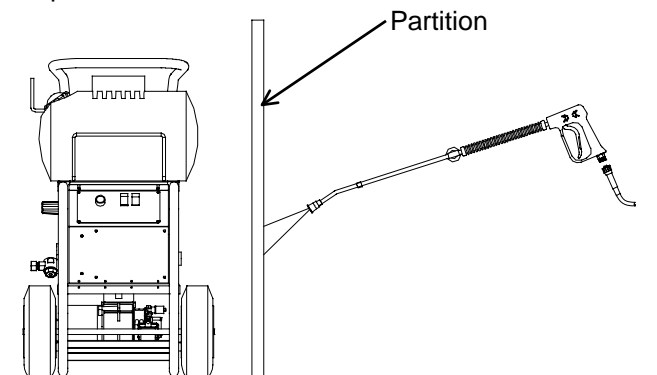

V.) Venting

DANGER: Do not run machine indoors or in an enclosed area without adequate ventilation, or in areas where flammable vapors, (gasoline, solvents, etc.) may be present. Do not vent exhaust gases into a wall, a ceiling, or a concealed space.

CAUTION: All venting must be in accordance with applicable federal and state laws, and local ordinances. Consult local heating contractors.

If the pressure washer is to be used in an enclosed area, a flue must be installed to vent burner exhaust to the outside atmosphere. Be sure the flue is the same size as the burner exhaust vent on the pressure washer lid. Poor draft will cause the pressure washer to soot and not operate properly. When selecting the location for installation, beware of poorly ventilated locations or areas where exhaust fans may cause an insufficient supply of oxygen. Proper combustion can only be obtained when there is a sufficient supply of oxygen available for the amount of fuel being burned. If it is necessary to install a unit in a poorly ventilated area, outside fresh air may have to be piped to the burner and a fan installed to bring sufficient air into the unit. Locate the pressure washer in such a manner that the flue will be as straight as possible and protrude through the roof

at a proper height and location to provide adequate draft. This oil fired unit must have a draft controller installed in the flue. A draft controller will permit proper upward air flow of exhaust flue gases.

VI.) Oil Burner

Burner Air Adjustment: The oil burner is preset and performance tested at the factory (elevation 1100 feet). A one-time initial correction of the burner for your location will pay off in economy, performance, and extended service life.

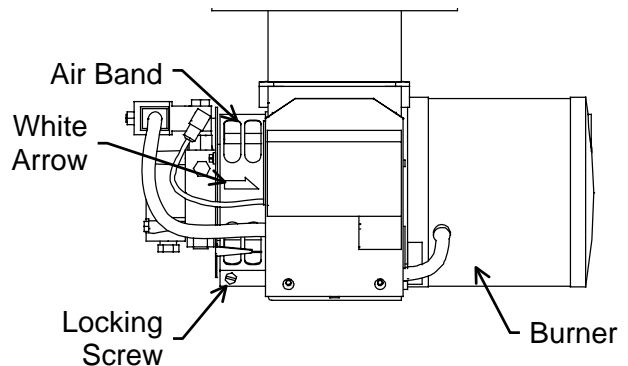

- 1.) Turn the pump and heat switches on (Refer to "Operation" for details). Have someone operate the spray gun so the burner fires.
- 2.) Loosen the locking screw and close the air band until black smoke appears from the burner exhaust vent. Note the position of the white arrow on the air band.
- 3.) Slowly open the air band until white smoke just starts to appear.
- 4.) Turn the air band half way back to the black smoke position previously noted. Tighten the locking screw.
- 5.) Fine tune the burner air by loosening the shutter lock screw and turning the shutter until the exhaust is cleanest. Tighten the shutter lock screw.

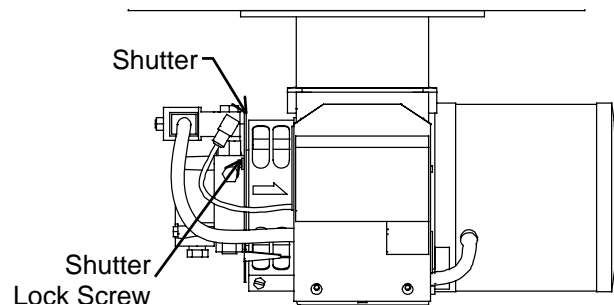

CAUTION: If white smoke appears from the burner exhaust vent during start-up or operation, discontinue use and readjust air bands.

NOTE: If a flue is installed, have a professional serviceman adjust your burner for a #1 or #2 smoke spot on the Bacharach scale.

Operating Instructions

Follow these instructions every time you use the pressure washer.

I.) Pre-Operation

- ☑ A.) Position the machine for easy access to all controls.
- ☑ B.) Position the machine on a solid surface, with less than a three degree slope, and so it is protected from external damage.
- ☑ C.) Position the machine so that ambient lighting is sufficient for the surface you are cleaning to be seen with ease. Use artificial light if needed.
- ☑ D.) Check hoses, fittings, wand, trigger gun and fuel connections for signs of wear, cracks and looseness, and replace as required.
- ☑ E.) Check and clean the nozzle orifice.
- ☑ F.) Check and clean the water inlet screen and filter.
- ☑ G.) Read entire manual, especially the important safety instructions listed on page 2.
- ☑ H.) Check and maintain proper oil level in the pump.

II.) Check Your Water Supply

- ☑ A.) Make sure the water supply is clean. Debris can cause excess pump wear and reduce performance.
- ☑ B.) An insufficient water supply will damage your pump. Make sure the water supply is steady and is 20% over the rated flow of your pump. Use a stopwatch to time how long it takes to fill a 5-gallon bucket with your garden hose.

Example: If the rated flow is = 3gpm
Then required flow = $3 \times 1.20 = 3.6\text{gpm}$
 $5\text{gallons} / 3.6\text{gpm} = 1.39\text{ minutes}$
 $1.39\text{min} \times 60\text{sec}/\text{min} = 83\text{ seconds}$
Therefore, you must be able to fill a 5 gallon bucket in 83 seconds or faster.

- ☑ C.) The water supply garden hose must have an inside diameter of at least 5/8". If the hose is more than 100 ft. long, the diameter must be at least 3/4".
- ☑ D.) Never use a reservoir tank as a water source. This pressure washer is designed for a pressurized water source such as a city water faucet. Sucking water out of a tank may cause pump cavitation and damage to your pump. However, the inlet pressure of the pump must not exceed 115 psi (8 bar).
- ☑ E.) Always use a flexible rubber hose for your water supply. Do not use rigid piping.
- ☑ F.) Do not pump flammable liquids or liquids containing incompatible chemicals or solvents.

III.) Before Starting

WARNING: Make sure all switches and controls are in the OFF position prior to plugging in the cord. DO NOT stand in water while plugging or unplugging electrical cord.

WARNING: Use a UL recognized receptacle protected by a ground fault interrupter and extension cord of proper voltage and amperage at all times.

1. Connect electrical cord to specified NEMA receptacle. See page 4.

WARNING: Check hoses, fittings, wand, trigger gun and fuel connections daily for signs of wear, cracks and looseness, and replace as required.

2. Connect water supply hose to the garden hose connector located on the pump.
3. Fill the burner fuel tank. We recommend kerosene because it burns cleanest. #1 grade home heating oil, #1 or #2 diesel can also be used. DO NOT USE GASOLINE OR CRANKCASE OIL.
4. If detergents will be used, only use detergents intended for pressure washers. Follow instructions on the detergent container.

IV.) To Start

DANGER: Do not point the spray wand at yourself or at any person. Bodily injury may result from water under high pressure.

WARNING: Wear eye, ear, hand, foot and skin protection at all times while operating this pressure washer.

IMPORTANT: The water must be turned on before starting. Running the pump dry will cause damage and void warranty.

1. Turn water supply ON.
2. Squeeze the trigger to allow air to purge from the system. (this step goes faster with the pressure nozzle removed)

V.) Attach Nozzle

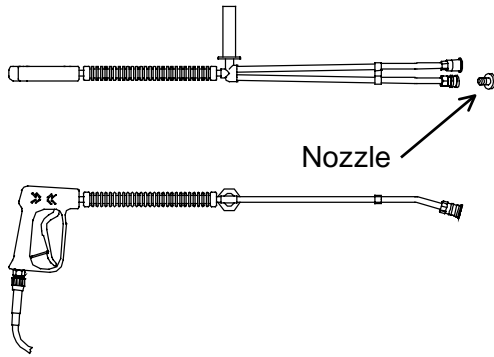

Color of Nozzle:	Spray Angle	Used For:
Red	0	Highest Impact
Yellow	15	Tough Stains/ Stripping
Green	25	General
White	40	Light Cleaning
Yellow	15	Steaming

Your pressure washer is equipped with five nozzles. To install a nozzle simply pull back the collar and push the nozzle into the coupler. Once the connection is made, pull on the nozzle to assure a tight connection.

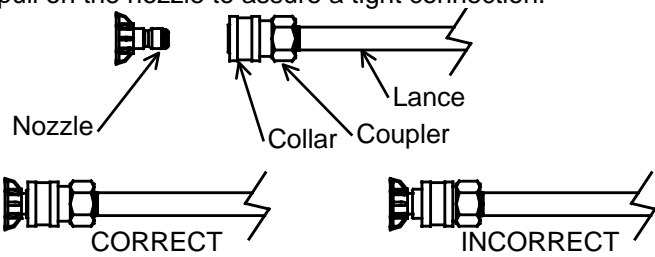

WARNING: Make sure the nozzle is correctly inserted. The nozzle may become a projectile if not inserted correctly. Do not attempt to use different types of nozzles that may not fit the coupler.

VI.) Turn the pump switch ON.

1. Make sure the hose is not kinked. A kinked hose will provide insufficient water supply to the pump and will reduce its life. Make sure the hose remains unkinked after moving the pressure washer.

VII.) For Hot Water

1. If HOT water is desired, make sure there is fuel in the fuel tank, turn the heat switch ON, and adjust the thermostat to the desired temperature(if applicable). The burner will fire when the trigger is squeezed. You may need to initially adjust your burner for peak performance. See the "Oil Burner" section under INSTALLATION. When the trigger is released or the [temp setting](#) is reached, the burner will automatically turn off.

IMPORTANT: Do not run the machine in hot mode without any fuel in the fuel tank. The fuel pump will be damaged if it is run dry.

To Clean

WARNING: Wear eye, ear, hand, foot and skin protection at all times while operating this pressure washer.

DANGER: Do not point the spray wand at yourself or at any person. Bodily injury may result from water under high pressure.

CAUTION: Be careful on painted or delicate surfaces, the pressure may damage the surface if the nozzle is too close.

IMPORTANT: Your spray gun is equipped with a built-in trigger safety latch to guard against accidental trigger actuation and potentially dangerous high-pressure spray. Rotate the safety latch to the locked position when not spraying.

NOTE: Your pressure washer is equipped with a low pressure chemical injector. You do not need to use chemicals for every job, however, the proper chemical used for the proper application can speed up cleaning jobs tremendously.

WARNING: Only use North Star pressure washer chemicals or chemicals specifically formulated for pressure washers. Follow the chemical manufacturer's recommendations. Understand all safety precautions and first aid for all chemicals.

1. Snap the quick couple chemical injector onto the high pressure water outlet and high pressure hose and submerge the suction strainer into the chemical solution.

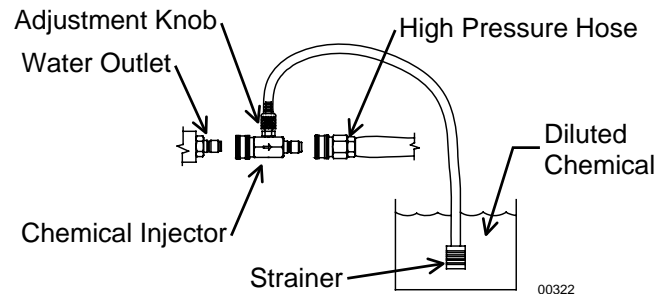

2. The amount of chemical applied can be changed by turning the chemical adjustment knob located on the chemical injector.

3. Rotate the grip on the dual lance wand to change to low pressure and start the detergent flow.

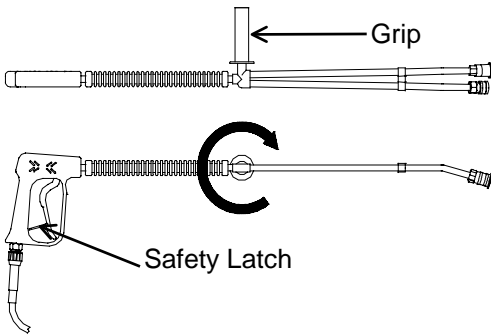

4. Spray detergent onto the surface and allow it to soak. Chemicals need time (dwell time) to work properly. Follow the chemical manufacturer's recommendations for dwell time.
5. Change back to high pressure by rotating the grip until water comes out the right lance only.
6. Hold the lance with two hands, have a sturdy stance.
7. Point lance at dirty surface and squeeze trigger.
8. Wash from the bottom to the top, using side to side motions. This washes away heavy dirt and allows the detergent to soak as you work toward the top.
9. Use the width of the spray pattern to wash in a wide path. Overlap spray paths for complete coverage.
10. The nozzle should be 12" to 24" from the work, closer for tough areas.

Caution: Be careful on painted or delicate surfaces, the pressure may damage the surface if the nozzle is too close.

11. Small parts should be washed in a basket so the pressure does not push them away. Larger, light weight parts should be clamped down.
12. The pressure washer is set to the maximum rated pressure when it leaves the factory. There are two easy ways to change your pressure.
 - a. Rotate the grip slightly to allow some flow to pass through the left lance. See step 3.

- b. Or, turn the black unloader knob counter clockwise.

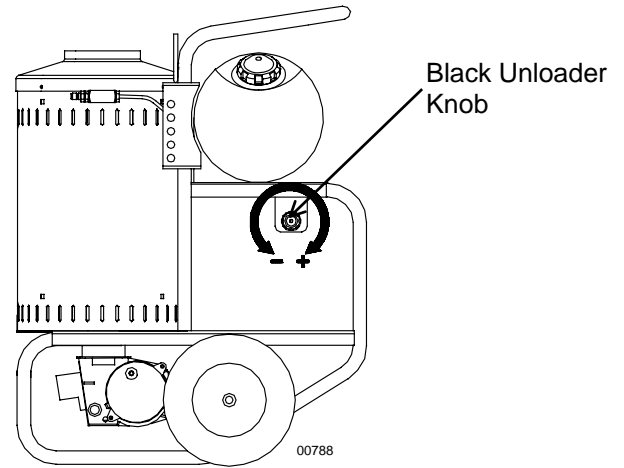

WARNING: Do not alter the unloader valve's maximum pressure. Excess pressures could cause serious injury and/or pump damage. Any alteration other than turning the adjustment knob will void your warranty.

For Steam (Optional)

1. Set the thermostat to 250°F.
2. Turn the Heat switch ON.
3. Insert the steam nozzle into the nozzle holder.

To Stop

1. If detergents were used, draw clear water through the detergent inlet line to purge detergent. Failure to do so may clog the chemical injector.
2. If the burner was used, turn off the "Heat" switch and pump cold water through the coil for 3 minutes. Insufficient cool down period of high pressure hose will cause excessive wear and eventual rupturing of hose.
3. Turn the pump switch OFF.
4. Turn OFF the water supply.
5. Squeeze the trigger to relieve the system pressure.

Safety Features

I.) Safety Relief

The safety relief valve is a backup safety feature. If the unloader malfunctions, the safety relief valve will open and relieve system pressure.

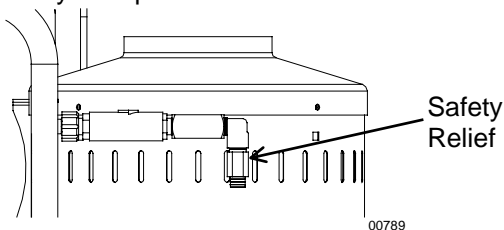

WARNING: If the safety relief valve ever discharges water, turn the unit off and do not use the machine. See a dealer or call Customer Service at 1-800-270-0810.

II.) High Temperature Limit

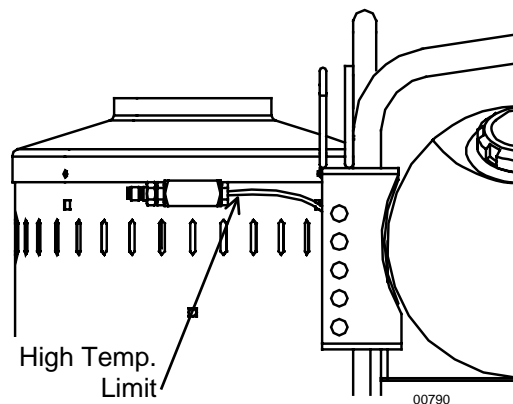

Maintenance Instructions

WARNING: Unauthorized machine modification or use of non-approved replacement parts may cause personal injury and/or property damage and will void the manufacturer warranty.

All mechanical equipment, no matter how well designed, will need repairs. A North Star pressure washer is no exception. At times, a North Star pressure washer may be inoperable because repairs are required. North Star Customer Service will assist in these repairs as needed, but if an inoperable pressure washer creates a major expense to your business then we strongly recommend the following:

1. Have someone on staff who is trained in the operation of the pressure washer and is capable of making minor repairs and performing all preventative maintenance procedures as outlined in the provided manuals.
2. Keep a stock of recommended service parts for maintenance and minor repairs.

Recommended Service Parts List

Following is a list of the service parts we recommend stocking.

Description	157321	157322	157325	157326
0° Nozzle	25302	25302	305280	305280
15° Nozzle	25309	25309	253010	253010
25° Nozzle	253091	253091	253017	253017
45° Nozzle	253024	253024	253025	253025
Steam Nozzle	-	305297	-	778945
Pump Oil	4043	22158	4043	22158
Chemical Injector	31934	31934	31934	31934
Spray Gun	2227	2227	2227	2227
30' Pressure Hose	31911	-	31911	-
50' Pressure Hose	-	31933	-	31933
Pump Seal Kit	AAAR1866	CA30453	AAAR2741	CA30453
Pump Valve Kit	AAAR1864	CA34052	AAAR1864	CA34052
Pump Inlet Valve Kit	-	CA34668	-	CA34668
Electrode Kit	RWB5780U	RWB5780U	RWB5780U	RWB5780U
Fuel Pump	RWB2460U	RWB2460U	RWB2460U	RWB2460U
Pressure Switch	777656	777656	777656	777656
Pressure Gauge	MV32154	MV32154	MV32154	MV32154
Fuel Filter Element	RCR12T	RCR12T	RCR12T	RCR12T

Maintenance Mode

Before performing any maintenance on the pressure washer, it must be placed in maintenance mode.

- A.) Turn off water supply
- B.) Bleed water from system
- C.) Turn off and unplug power cord

Maintenance Schedule

What to Check	When To Check	What to Do
Fuel Filter	500 hrs	Change
Inlet Filter	Each Use	Clean
Tires	Each Use	Check Pressure
Hoses	Each Use	Check for Wear
Bolts	Each Use	Check for Loose Bolts

Cleaning The Inlet Filter

WARNING: Check whether dangerous chemicals have been used, and take precautions when handling filters.

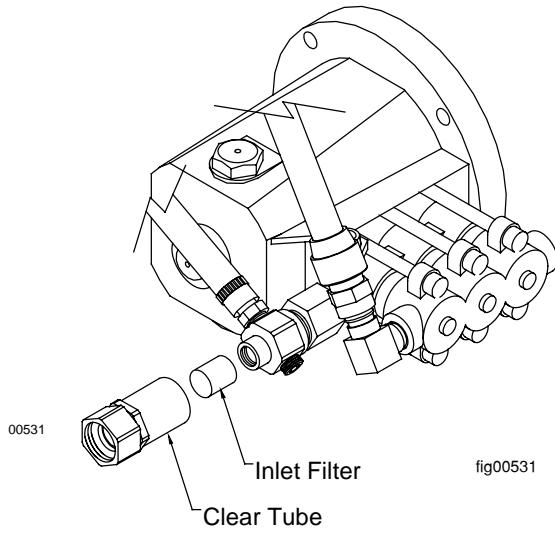

- A.) Unscrew clear tube by hand.
- B.) Remove Inlet filter
- C.) Run water through to clean filter

Checking the Tire Air Pressure

- A.) Remove air fill cap
- B.) Fill tire to 20psi (1.4bar)
- C.) Replace air fill cap

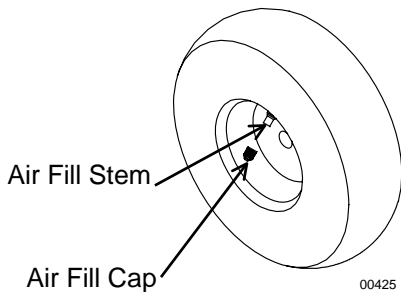

Burner Fuel Filter

Drain water which has accumulated in the fuel filter bowl and replace the filter as needed.

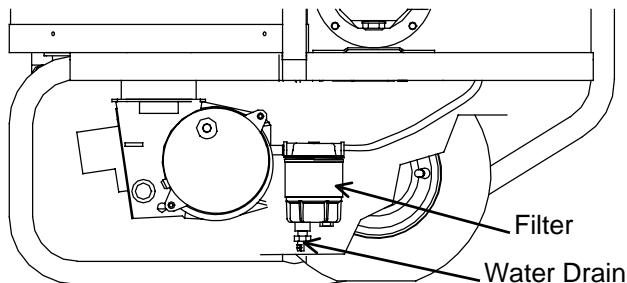

Checking the Hoses

WARNING: Do not use a finger or skin to check for leaks. Escaping fluid under pressure has sufficient force to penetrate the skin, causing serious injury. Do not operate the pressure washer if the hose is cracked, worn, or leaking.

- A.) Check all hoses for leaks
- B.) Check all hoses of worn areas

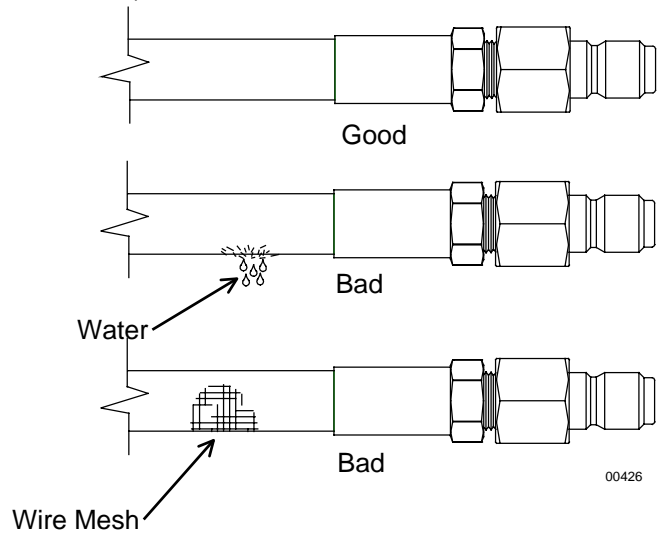

Changing The Pump Oil

*Change oil after first 50 hours, then every 3 months or 500 hours

- 1.) Remove oil drain plug
- 2.) Drain pump oil
- 3.) Replace oil drain plug
- 4.) Fill pump with SAE 30 non-detergent pump oil.
- 5.) Use dip stick to fill to proper level or sight glass on Cat pumps.

Quantities Of Fluid

Pump	Type of Fluid	QTY
AR	SAE 30*	11.0oz (0.33L)
CAT	SAE 30**	14.0oz (0.41L)

*Non-Detergent Oil (order pump oil Item #4043)

**Non-Detergent Oil (order pump oil Item #22158)

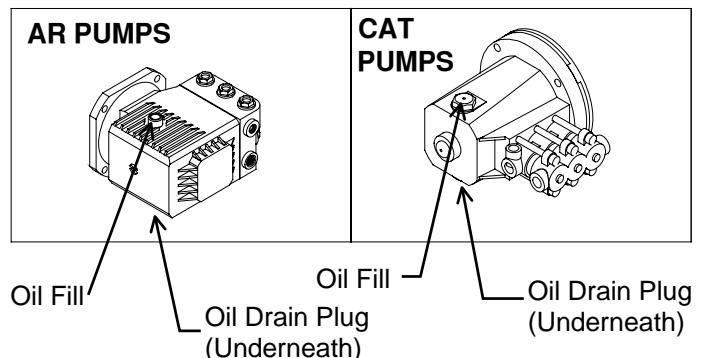

Coil Descaling

In hard water areas, scale build-up within the heating coil will occur. Scale deposits will decrease the water temperature rise and may eventually clog the heating coil.

1. Mix scale remover in a 5 gallon bucket and elevate the bucket so it is higher than the pump.
2. Attach the high pressure hose to the high pressure water outlet on the machine, do not hook up the spray gun.
3. Place the other end of the high pressure hose in the 5 gallon bucket.
4. Attach a short length of hose to the garden hose inlet on the pump.
5. Prime the pump by filling the hose with water, then place the end of the hose in the bucket.

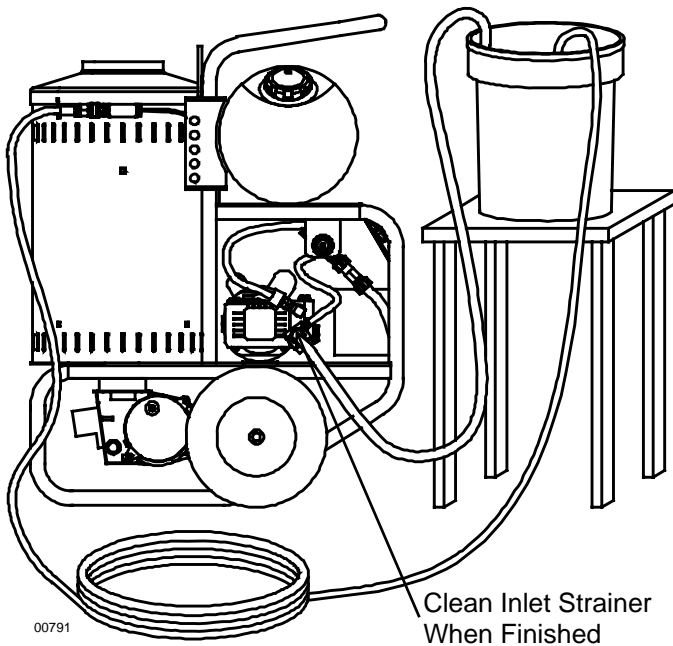

6. Run the pressure washer in cold mode for 1 to 3 hours recirculating the cleaning solution.

Warning: Do not run the burner.

7. Dispose of the cleaning solution where it is not harmful to animals or the environment.
8. Flush with fresh water and clean the inlet strainer when finished.

Coil Desooting

Poor grades of fuel oil or inadequate combustion air will cause heavy soot build-up on the outside surface of the heating coil. These deposits will insulate the coil. This will restrict the air flow through the coil, further aggravating the soot build-up.

Most coils will never require desooting. However, to desoot a coil...

1. Wear protective clothing, goggles, and gloves.
2. Remove the fittings from the inlet and outlet of the coil.
3. Remove the lid from the heating chamber and hoist the coil out. Be careful, the coil is very heavy.

Important: Be careful not to damage the threads on the coil inlet and outlet. If the threads get damaged, it will be hard to reconnect and seal the fittings on the coil inlet and outlet.

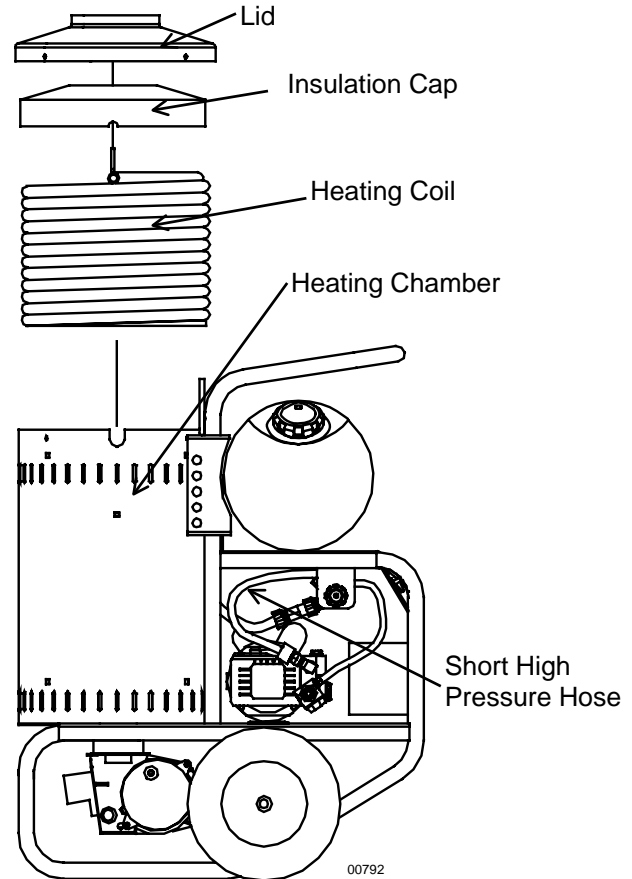

4. Clean the coil.
5. Reassemble the coil to the machine. Make sure the white insulation remains in place.
6. Make sure all fittings are tight before using the machine. Use thread sealant on all threads.

Electrodes

On a yearly basis the electrodes should be inspected and any necessary adjustments made.

1. Tip the machine back until it rests on the frame.

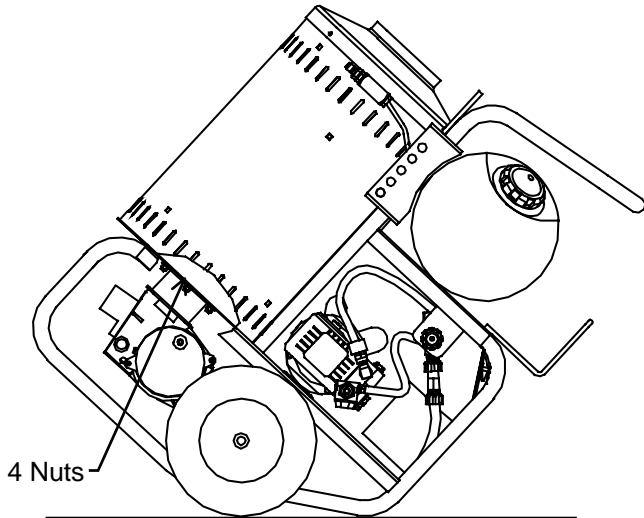

00793

2. Remove the 4 nuts that attach the burner to the heating chamber. You do not have to disconnect the fuel lines or the electric cords.
3. Let the burner fall away from the heat exchanger.

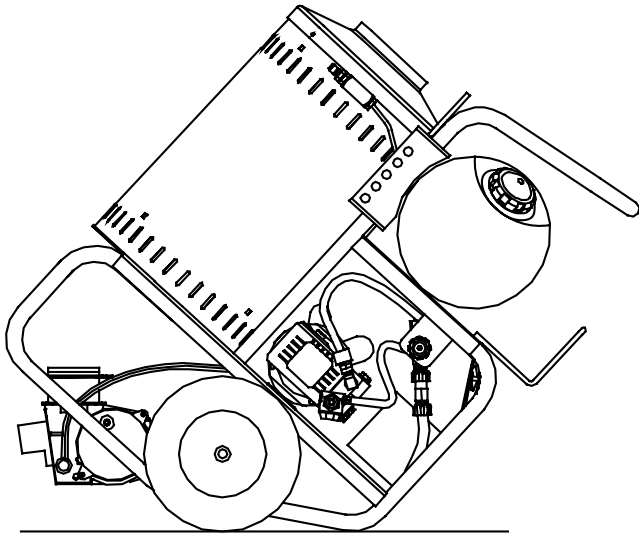

00794

4. Clean off carbon deposits which may have accumulated on the tips of the electrodes.
5. Reset the spacing as shown below.

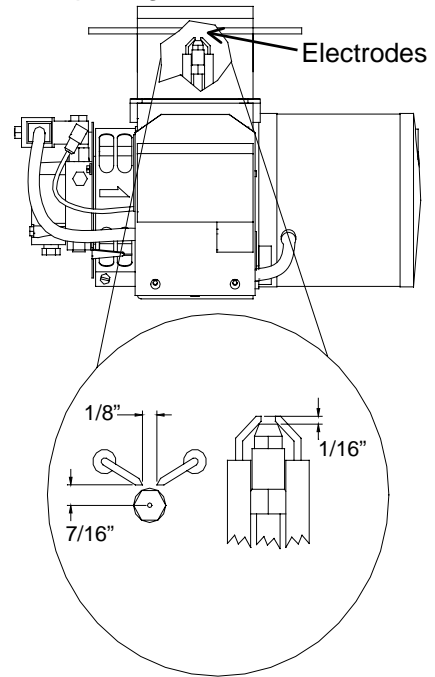

Moving and Handling Instructions

Maneuvering Your Pressure Washer

- 1.) Pull the handle back with both hands.
- 2.) Rotate the handle downward to a comfortable height.
- 3.) Push the pressure washer forward as you walk.

Lifting Your Pressure Washer

- 1.) To reduce risk of injury, it is recommended to use a hoist to lift this pressure washer.
- 2.) Lift from lifting point

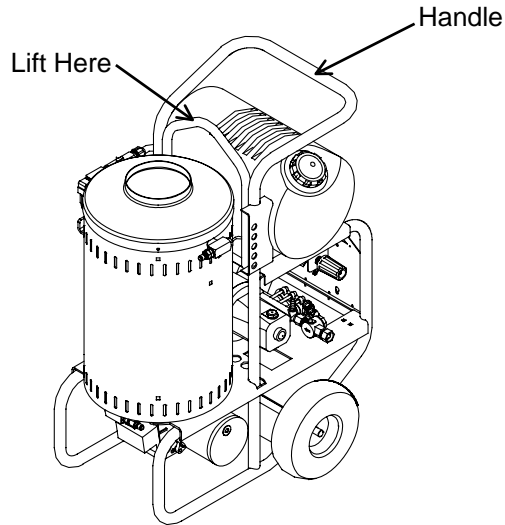

Long Term Storage

During cold weather, store the pressure washer indoors and move it outdoors before starting. Follow these instructions to prevent the pump from freezing during storage.

Winter Storage:

Items needed: 12" piece of garden hose or equivalent, funnel and RV antifreeze (approximately 2gallons).

- 1.) Attach the garden hose with funnel to the pump inlet (see illustration).
- 2.) Pour RV antifreeze into the funnel.
- 3.) Turn the unit on, burner off.
- 4.) Let the pump run until antifreeze comes out the high pressure outlet.
- 5.) It will take about 1.5 gallons of antifreeze to fill the pump and heat exchanger coil.
- 6.) Drain all water from the high pressure hose. Depress trigger on gun and drain all water out of gun/lance.

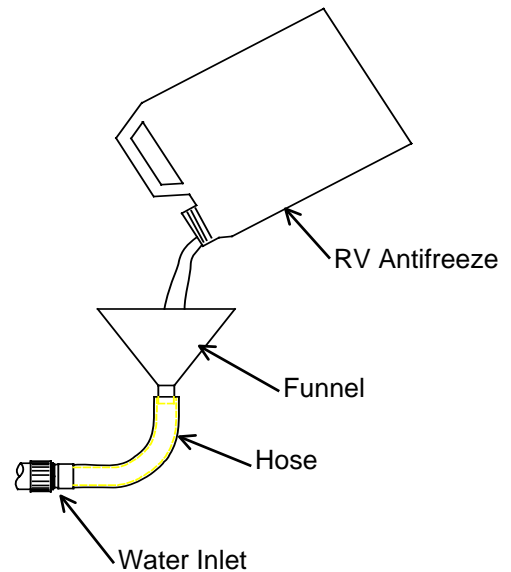

Troubleshooting Guide

Pressure Washer Will Not Run - No Power

Causes	Solutions
Machine not plugged in	Plug machine in
GFCI tripped	Make sure machine is dry. Press RESET on the GFCI
Machine turned OFF	Turn Pump switch ON
Line circuit breaker tripped	Check for tripped circuit breaker in building

Circuit Breaker Trips During Operation

Causes	Solutions
Voltage too low	Check the voltage
Circuit Breaker Overloaded	Make sure to use NEMA specified receptacle. Make sure there is no other equipment using the same circuit. - see <i>Specifications</i>
Pressure set too high	Check/adjust pressure setting on unloader.

Pressure Washer Runs But No Pressure

Causes	Solutions
Partially clogged or damaged nozzle	Clean or replace nozzle
Low water flow	Make sure the water supply is more than 4 gpm

Pressure Washer Surges Or Cycles While In Bypass

Causes	Solutions
Leak between unloader and gun.	Check all connections between unloader and gun for leaks. Tighten loose components and replace damaged components.
Gun leaking internally	Replace spray gun

Smoke From Heat Exchanger

Causes	Solutions
Air band not adjusted properly due to different elevation	Adjust the air band until the burner burns cleanly. See <i>Oil Burner</i> under <i>Installation Instructions</i>
Poor quality fuel	Use Kerosene for the cleanest burn

Water Not Heating Sufficiently

Causes	Solutions
Scale build-up in coil	See <i>Coil Descaling</i> under <i>Maintenance Instructions</i>
Coil is full of soot	See <i>Coil Desooting</i> under <i>Maintenance Instructions</i>

Safety Relief Valve Sprays Water

Causes	Solutions
Unloader/Burner Control Problem	Call customer service

Poor Or No Detergent Supply

Causes	Solutions
Soap control knob set too low.	Adjust soap control knob
Inadequate detergent supply	Refill detergent container. Make sure the chemical strainer is fully submerged
High pressure hose too long	Use less hose. Move machine closer to the work.
Chemical strainer or injector clogged	Clean the strainer and injector. Always start with a clean detergent container. Run clean water through the injector after each use.

HOTPW 157321,157322,157325, 157326

Parts Breakdown

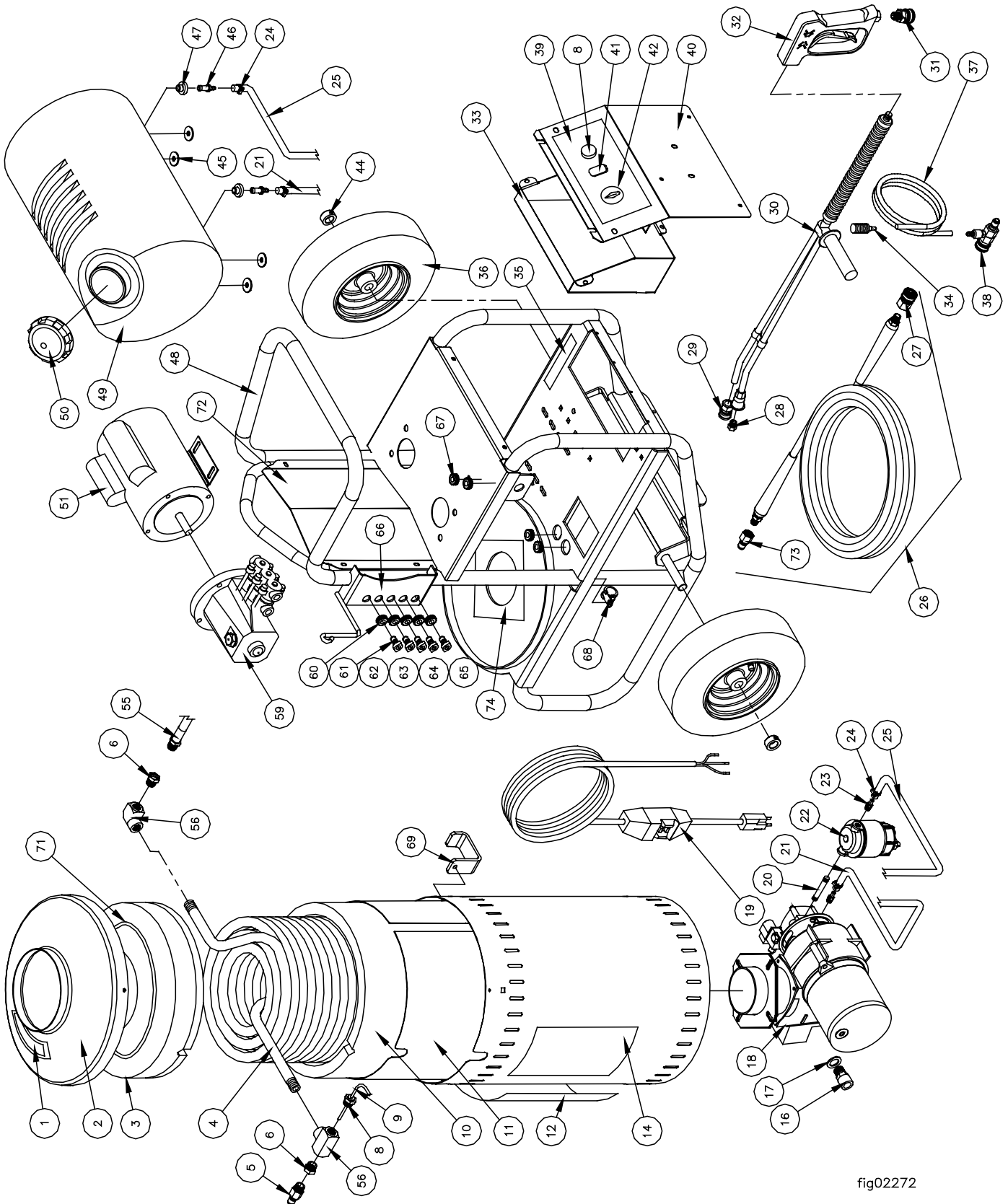

fig02272

HOTPWR- 157321,157322,157325,157326

ITEM	PART#	DESCRIPTION	QTY	MODEL
1	305410	Label, Caution Hot	1	all
2	35331	Lid, Heat Exchanger	1	all
3	38398	Insulation Cap	1	all
4	33573	Coil	1	all
5	777913	3/8" Nipple	2	all
6	30048	1/2" NPT x 3/8": NPT Nipple	2	all
7	305208	1/2" Tee, Plated Steel	2	all
8	305236	High Temp. Limit Switch	1	157321, 157325
	305422	Adjustable Thermostat,	1	157322, 157326
9	30501	1/4" Split Loom	2ft	157322, 157326
10	33387	Insulation Can	1	all
11	777658	Fire Chamber	1	all
12	305230	Label, Professional Series	1	157321, 157325
	305248	Label, Industrial Series	1	157322, 157326
13	305427	Label, Pictorial Warnings	1	all
14	36180	Vented Wrap, Stainless	1	all
16	22502	Strain Relief, 1/2" NPT	1	all
17	305267	Nut, 1/2" NPT for Strain Relief	1	all
18	777166	Burner	1	157321, 157322
	777167	Burner	1	157325, 157326
19	30823	Power Cord, w/GFI, 115V	1	157321, 157322
	777122	Power Cord, w/ GFI, 230V	1	157325, 157326
20	305239	1/4" NPT Nipple 3" Long	1	all
21	777345	Hose, Fuel Line	30"	all
22	32308	Fuel Filter	1	all
23	777340	1/4"NPT x 1/4" Hose Barb	2	all
24	777834	Hose Clamp, 1/4"	4	all
25	777345	Hose, Fuel Line	30"	all
26	31911	30 ft. x 3/8" Hose Yellow	1	157321, 157325
	31914	50 ft. x 3/8" Hose, Yellow	1	157322, 157326
27	313108	3/8" Quick Coupler, Female	1	all
28	30507	Nozzle, 1/4" NPT, Chemical		all
29	2234	1/4" Nozzle Quick Coupler	1	all
30	319152	Dual Lance	1	all
31	313107	3/8" Quick Coupler, Male	1	all
32	2227	Spray Gun. 3/8" FPT Inlet	1	all
33	777247	Control Box	1	all
34	2212	Chemical Strainer	1	all
35	ST12	Electric Shock Label	1	all
36	30388	Wheel/Tire Assembly	2	all
37	777165	Clear Hose Chemical Line	3ft	all
38	31934	Chemical Injector	1	all

ITEM	PART #	DESCRIPTION	QTY	MODEL
39	37511	Control Decal, Pro Series	1	157321, 157325
	37512	Control Decal, Ind Series	1	157322, 157326
40	37509	Service Panel	1	all
41	305180	Switch, 120V Lamp	1	157321, 157322
	305261	Switch, 240V Lamp	1	157325, 157326
42	37508	Control Switch	1	all
44	305200	Locking Collar	2	all
45	30754	Leather Washer	4	all
46	31976	1/4"Fuel Tank Fitting	2	all
47	306401	Rubber Seal, Fuel Tank	2	all
48	777795	Frame	1	all
49	3054007	Fuel Tank	1	all
50	305206	Fuel Cap	1	all
51	777616	Motor, 1.5HP	1	157321, 157322
	778670	Motor, 5HP	1	157326
55	37549	High Pressure Hose Assy	1	all
56	777797	1/2" NPT Elbow	1	all
59	NPN	Pump Assembly	1	all
60	777111	Grommet	5	all
61	25302	Nozzle, 0°, #4.0 (Red)	1	157321, 157322
	305280	Nozzle, 0°, #5.0 (Red)	1	157325, 157326
62	25309	Nozzle, 15°, #4.0 (Yellow)	1	157321, 157322
	253010	Nozzle, 15°, #5.0 (Yellow)	1	157325, 157326
63	253091	Nozzle, 25°, #4.0 (Green)	1	157321, 157322
	253017	Nozzle, 25°, #5.0 (Green)	1	157325, 157326
64	253024	Nozzle, 40°, #4.0 (White)	1	157321, 157322
	253025	Nozzle, 40°, #5.0 (White)	1	157325, 157326
65	305297	Nozzle, 15°, Steam	1	157322
	778945	Nozzle, 15°, Steam	1	157326
66	305233	Label, Nozzle Identification	1	157321, 157325
	305296	Label, Nozzle ID w/ Steam	1	157322, 157326
67	777146	Grommet	4	all
69	305411	Cord Hanger	1	all
71	36302	Fiberglass Rope	3ft	all
72	38400	Heat Shield	1	all
73	313109	Quick Coupler	1	all
74	38120	Insulation Gasket	1	all

HOTPWR- 157321,157322,157325,157326

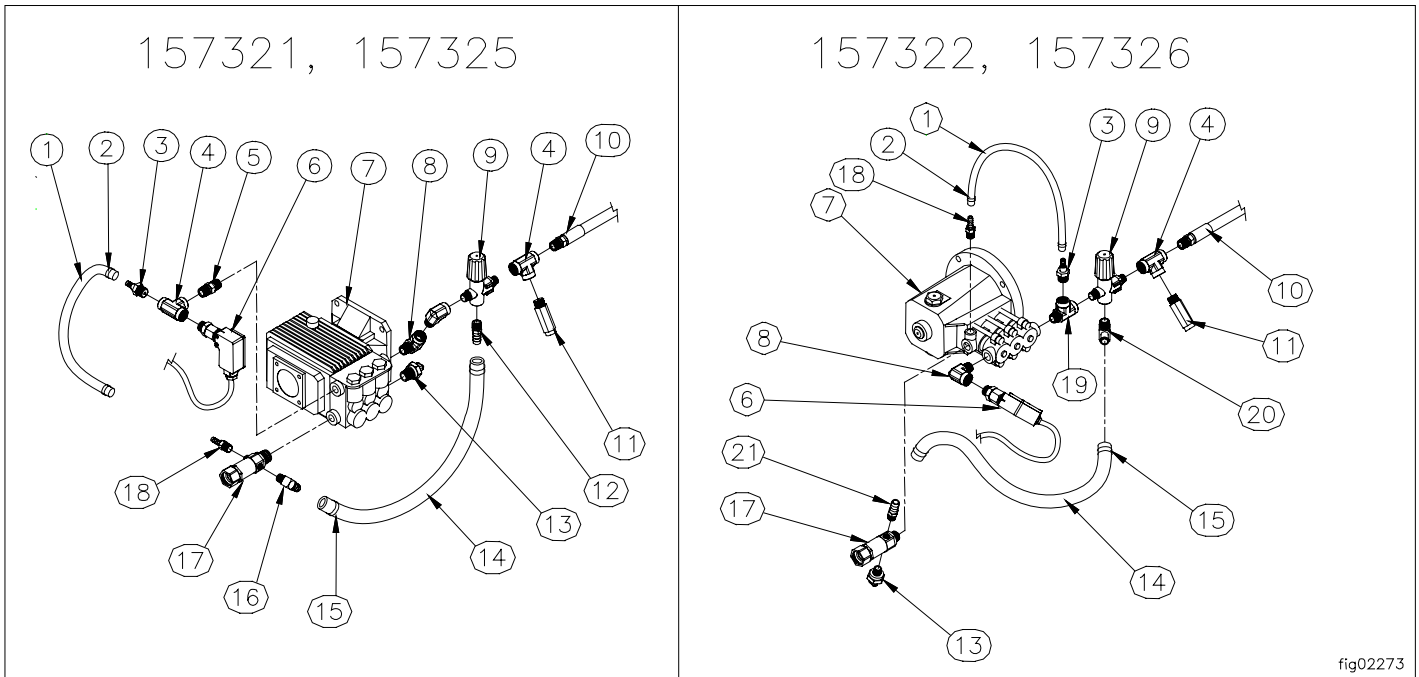
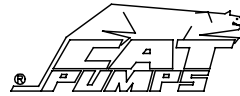
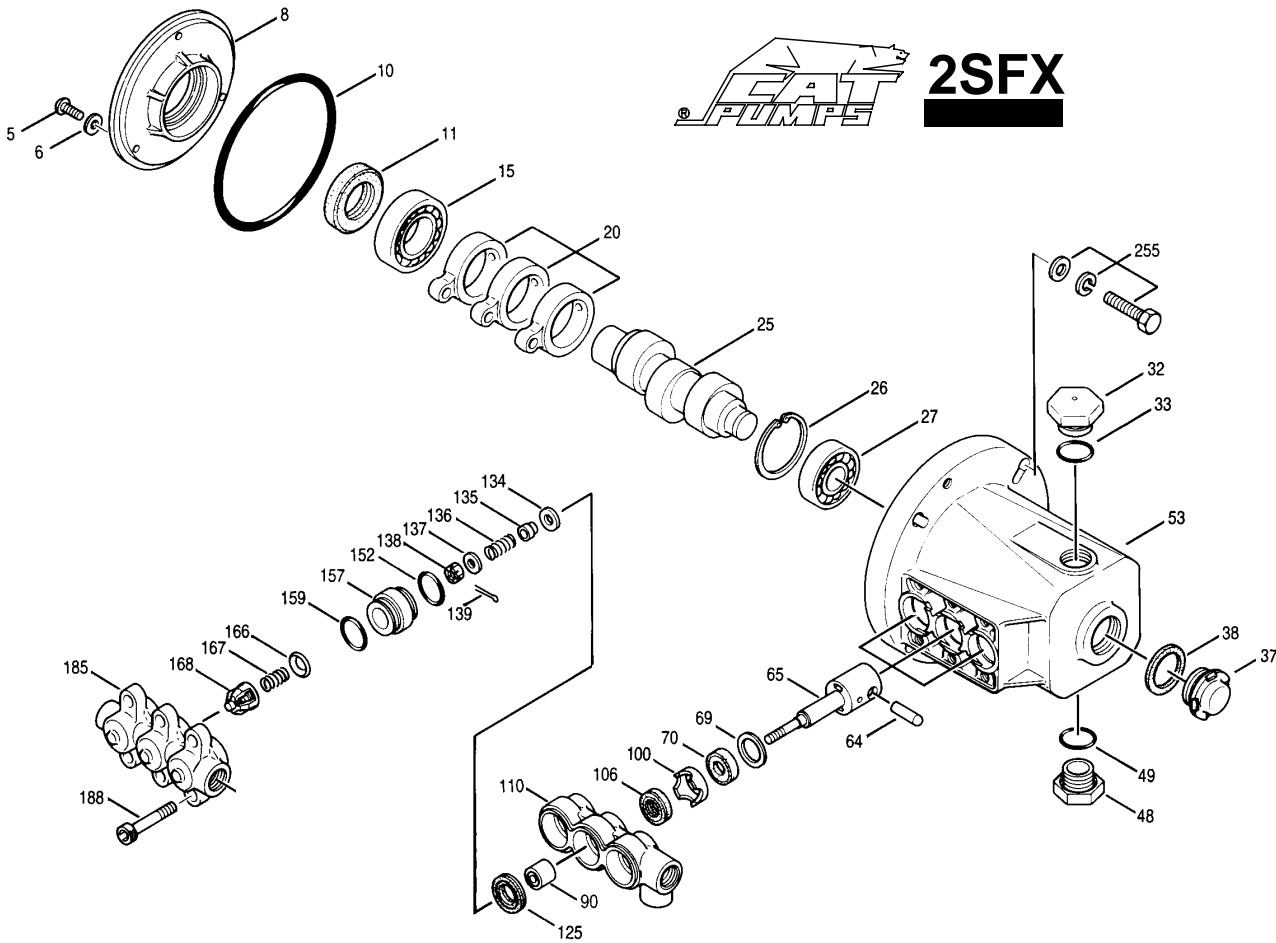

fig02273

ITEM	PART #	DESCRIPTION	QTY	MODEL
1	777165	¼" hose	12"	all
2	777834	Hose clamp	2	all
3	38584	Easy start valve	1	all
4	777411	3/8 tee	2	157321,157325
	777411	3/8 tee	1	157322, 157326
5	2296	3/8 hex nipple	1	157321, 157325
6	777656	Pressure switch	1	all
7	305301	AR XTV pump, 2gpm	1	157321
	305289	Cat 2SF pump, 2gpm	1	157322
	305281	AR XMV pump, 3.5gpm	1	157325
	305306	Cat 2SF pump, 3.5gpm	1	157326
8	777410	3/8 street elbow	2	157321,157325
	777410	3/8 street elbow	1	157322, 157326
9	777749	Unloader	1	157322,157326
10	37549	High pressure hose assembly	1	all
11	35104	Safety relief valve	1	157321, 157322
	22392	Safety relief valve	1	157325 157326
12	777839	3/8npt x ½ hose barb	1	157321, 157325
13	777836	Thermal protector	1	157321,157325
	35918	Thermal protector	1	157322, 157326
14	2264	½" hose	12"	all
15	777119	Hose clamp	2	all
16	38626	1/4npt x ½ hose barb	1	157321, 157325
17	35169	Inlet filter	1	157321,157325
	38596	Inlet filter	1	157322, 157326
18	777340	1/4npt x ¼ hose barb	1	all
19	777347	3/8 street tee	1	157322, 157326
20	32808	3/8npt x ½ hose barb elbow	1	157322, 157326
21	777840	¼npt x ½ hose barb	1	157322, 157326



2SFX



ITEM	PART #	DESCRIPTION	MODEL	QTY
5	89551	Screw, HHC (M6x16)	all	3
6	150810	Washer, Seal (M6)	all	3
8	44857	Cover, Bearing, Inner	all	1
10	14044	O-Ring Bearing Cover	all	1
11	44859	Seal, Oil	all	1
15	14488	Bearing, Ball, Inner	all	1
20	45876	Rod, Connecting	all	3
25	44929	Crankshaft, 3450RPM, 5/8", 3.3mm	2SFX22ES	1
	542441	Crankshaft, 3450RPM, 3/4", 4.7mm	2SFX30GS	1
	45100	Crankshaft, 3450RPM, 3/4", 5.6mm	2SFX35GS	1
26	12385	Ring, Retaining	all	1
27	15710	Bearing, Ball, Outer	all	1
32	45690	Cap, Oil Filler	all	1
33	14179	O-Ring, Oil Filler Cap - 70	all	1
37	43987	Gauge, Bubble Oil	all	1
38	44428	Gasket, Flat Flex, Oil Gauge - 80	all	1
48	44842	Plug, Drain (1/2" NPT)	all	1
49	14179	O-Ring, Drain Plug - 70	all	1
53	541018	Crankcase	all	1
64	16948	Rist, Pin	all	3
65	540073	Rod, Plunger	all	3
69	20017	Washer (M24)	all	3
70	25461	Seal, Oil	all	3
100	44869	Retainer, Seal	all	3
106	44876	LPS w/S-Spg	all	3
110	44874	Manifold, Inlet	all	1
124	45847	Ceramic Plunger	all	3
125	43245	HPS w/S PS	all	3
134	45854	Valve, Inlet	all	3
135	44871	Spacer	all	3

ITEM	PART #	DESCRIPTION	QTY	
136	44872	Spring, Inlet Valve	all	3
137	88575	Washer, Conical (M6)	all	3
138	81240	Nut, Hex (M6)	all	3
152	26089	O-Ring, Adapter - 80	all	3
157	45859	Spacer, Discharge, Seat	all	3
159	26089	O-Ring, Adapter - 80	all	3
166	43723	Valve	all	3
167	541062	Spring	all	3
168	44565	Retainer, Spring	all	3
185	44879	Manifold, Discharge	all	1
188	87859	Screw, HSH (M8x75)	all	6
255	30517	Kit, Bolt Mount	all	1

VALVE KIT

34056		
ITEM	PART #	QTY
152	26089	3
157	45859	3
159	26089	3
166	43723	3
167	541062	3
168	44565	3

INLET VALVE KIT

34668		
ITEM	PART #	QTY
134	45854	3
135	44871	3
136	44872	3
137	88575	3
138	81240	3
152	26089	3
159	26089	3

SEAL KIT

34053		
ITEM	PART #	QTY
106	44876	3
125	43245	3
152	26089	3
159	26089	3

AR XMV35G25D-F23

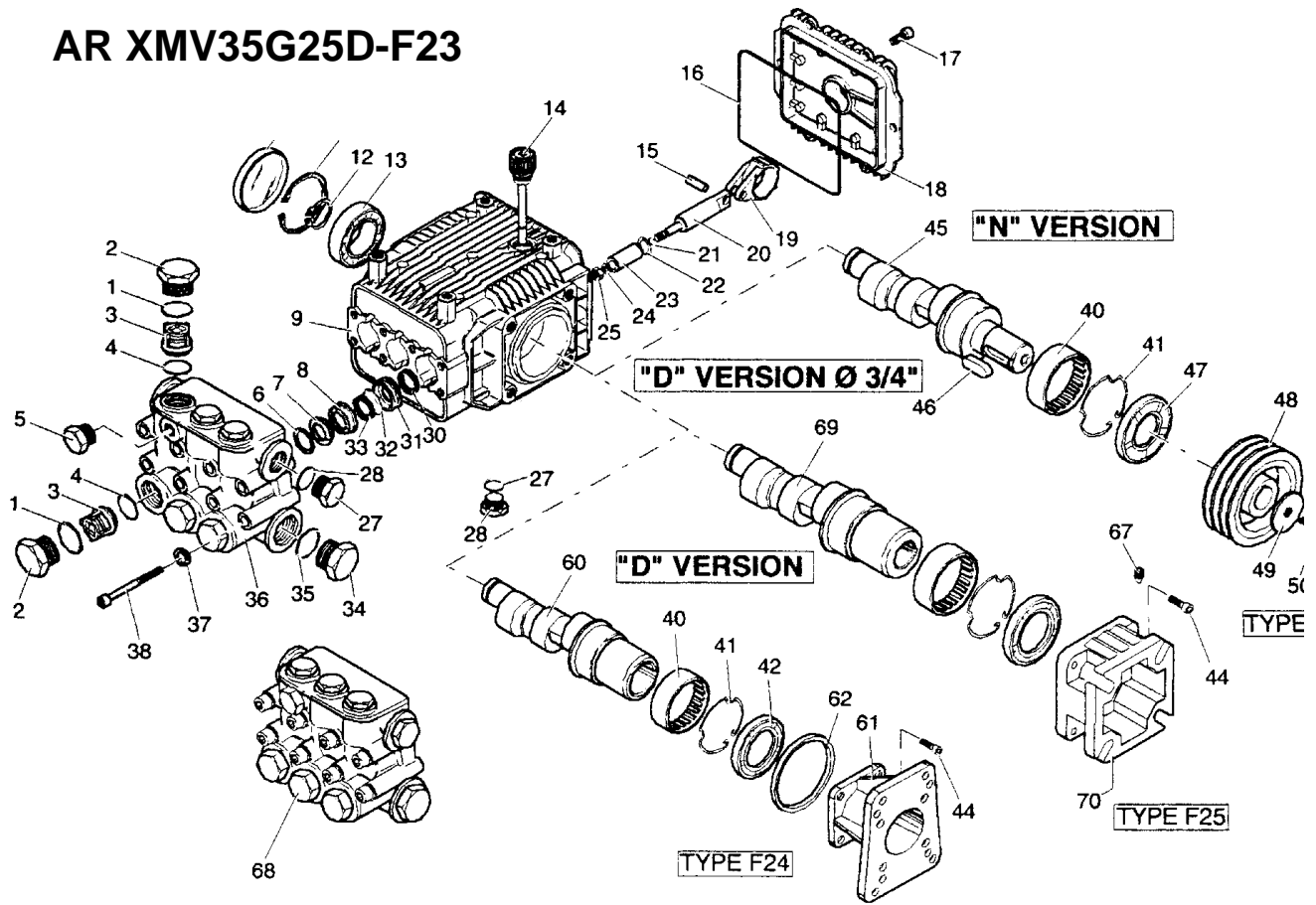

ITEM	PART #	DESCRIPTION	QTY
1	960160	O-Ring	6
2	1260162	Plug	6
3	1269050	Complete Valve	6
4	880830	O-Ring	6
5	620301	Plug	1
6	1780130	Support Ring	3
7	1260130	Gasket	3
8	1780090	Piston Guide	3
9	1780010	Pump Body	1
10	1266740	Cap	1
11	1260790	Circlip	1
12	1780550	Snap Ring	1
13	1780490	Bearing	1
14	880130	Oil Cap	1
15	1780050	Piston Ring	3
16	1780510	O-Ring	1
17	1200430	Screw	6
18	1780010	Complete Cover	1
19	1780040	Con Rod	3
20	1780060	Guiding Piston	3
21	480480	O-Ring	3
22	1260091	Spacer Disc	3
23	1780070	Piston	3
24	1260100	Piston Washer	3
25	1260110	Nut	3
27	740290	O-Ring	2
28	880530	Plug	2
30	1260460	Seal	3

ITEM	PART #	DESCRIPTION	QTY
31	1780100	Rear Piston Guide	3
32	770260	O-Ring	2
33	1260440	Gasket	3
34	820360	Plug	1
35	180101	O-Ring	1
36	1780380	Head	1
37	1381550	Washer	8
38	680570	Screw	8
40	1321190	Bearing	1
41	1321080	Snap Ring	1
42	480671	Seal	1
44	180030	Screw	4
60	1780630	Hollow Shaft	1
61	1780910	F33 Flange	1
62	1780430	Bushing	1

VALVE KIT

1864		
ITEM	PART #	QTY
3	1269050	6
4	880830	6

WATER SEAL KIT

2741		
ITEM	PART #	QTY
7	1260130	3
32	770260	3
33	1260440	3

AR XTV2G15EBA-F8 AR XTV3G16D-F8

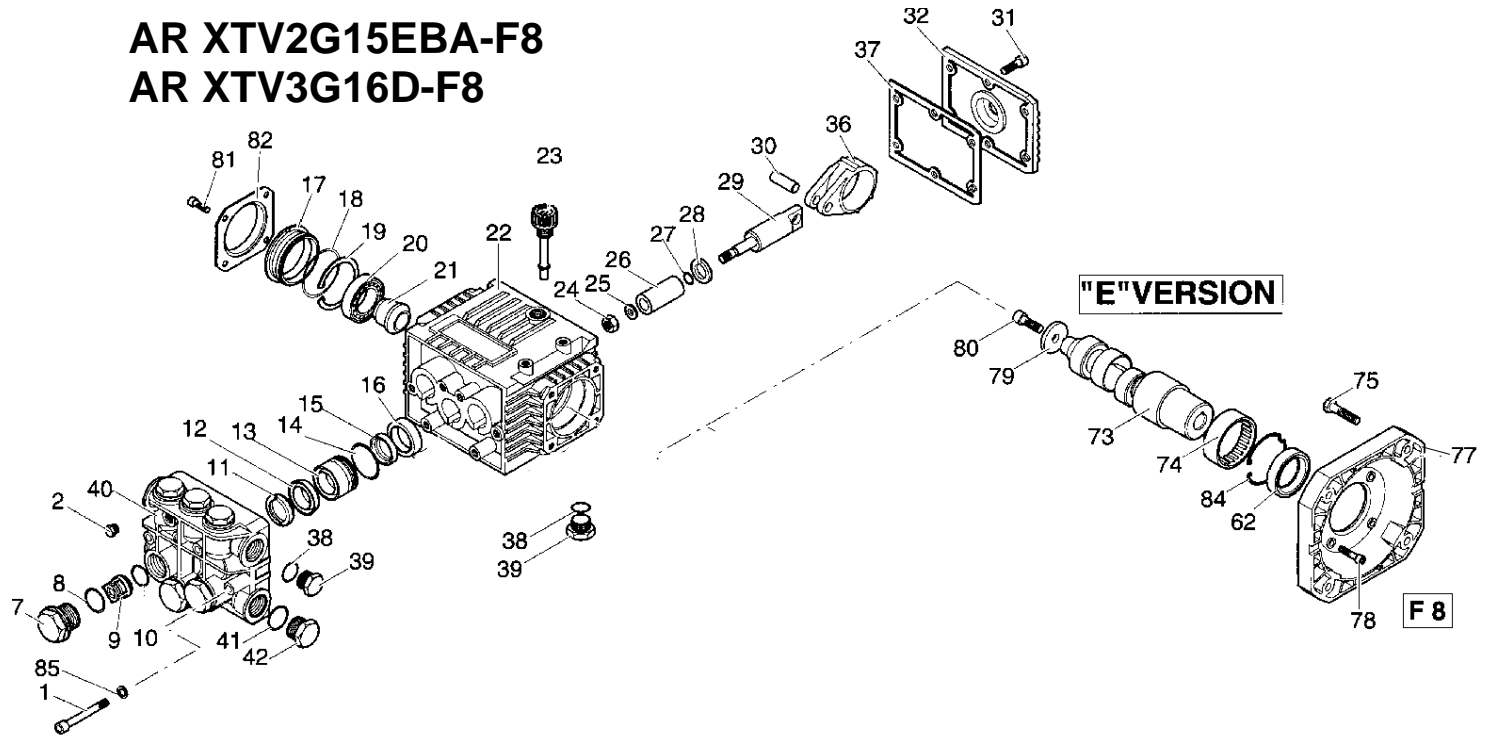

ITEM	PART #	DESCRIPTION	QTY
1	1322730	Head Bolt TCEI M6x60	6
2	620301	Screw	1
7	1260160	Valve Cap	6
8	960160	O-Ring	6
9	1269050	Complete Valve	6
10	880830	O-Ring	6
11	1260140	Support Ring	3
12	1260130	Packaging Gasket	3
13	1260151	Piston Guide	3
14	1260420	O-Ring	3
15	1260440	Packaging Seal Gasket	3
16	1260460	Piston Oil Seal	3
17	1320320	Shaft Side Plug	1
18	1320360	O-Ring	1
19	1260790	Circlip	1
20	1320370	Bearing	1
21	1320330	Bushing	1
22	1320010	Pump Body	1
23	880130	Dip Stick	1
24	1260110	Screw	3
25	1260100	Copper Washer	3
26	1260120	Piston	3
27	480480	O-Ring	3
28	1260091	Disc Separator	3
29	1260070	Piston Guide	3
30	1260080	Piston Pin	3
31	1260760	Screw	6
32	1321030	Rear Cover	1
36	1260060	Con Rod	3
37	1260040	Rear Gasket Cover	1
38	740290	O-Ring	3
39	880530	Oil Drain tap Bolt	2
40	1320021	Pump Head	1

ITEM	PART #	DESCRIPTION	QTY
41	180101	O-Ring	1
42	820360	Head Tap Bolt	1
62	480671	Seal Ring	1
73	1321820	Shaft(1572211)	1
73	1321830	Shaft(1572231)	1
74	1321190	Ring Bearing	1
75	650610	Bolt	4
77	1320060	Type F8 Flange	1
78	1200430	Bolt/Flange Motor	4
79	780230	Washer	1
80	780060	Bolt	1
81	1321780	Bolt	4
82	1321420	Side Cover	1
83	1260790	Circlip	1
84	1321080	Snap Ring	1

VALVE KIT

1854		
ITEM	PART #	QTY
9	1269050	6
10	880830	6

WATER SEAL KIT

1866		
ITEM	PART #	QTY
11	1260140	3
12	1260130	3
14	1260420	3
15	1260440	3

SWITCH BOX WIRING

MODELS WITH ADJUSTABLE TEMP

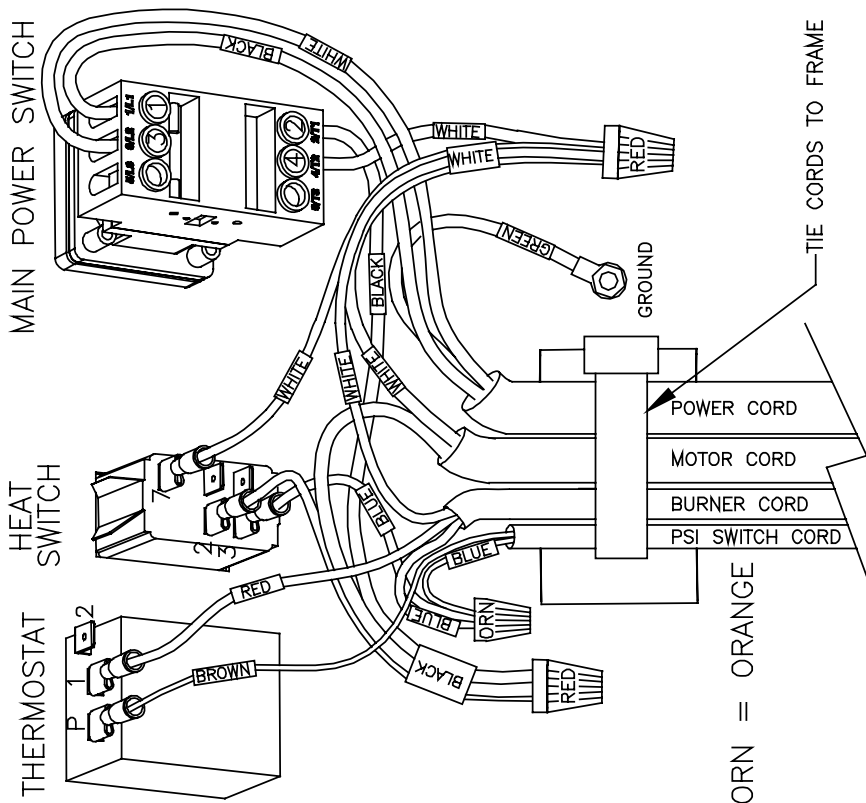

MODELS W/OUT ADJUSTABLE TEMP

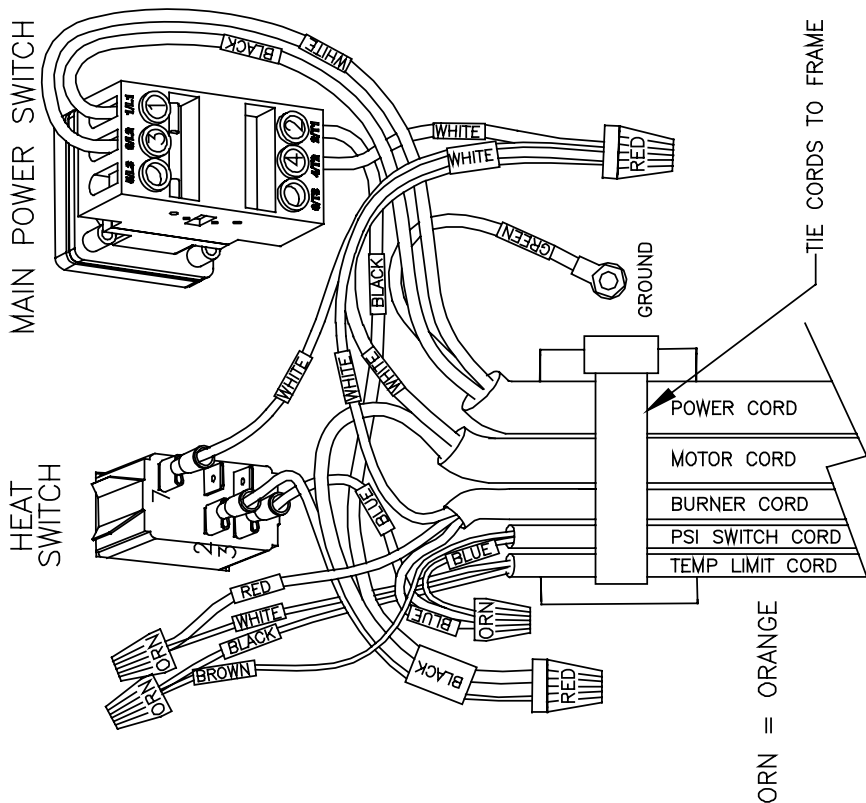

1.5 HP MOTOR WIRING

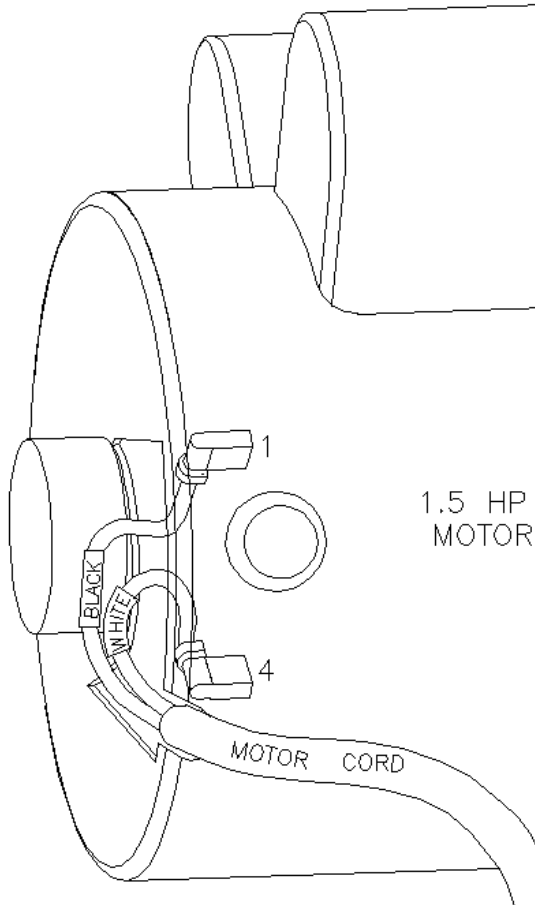

5 HP MOTOR WIRING

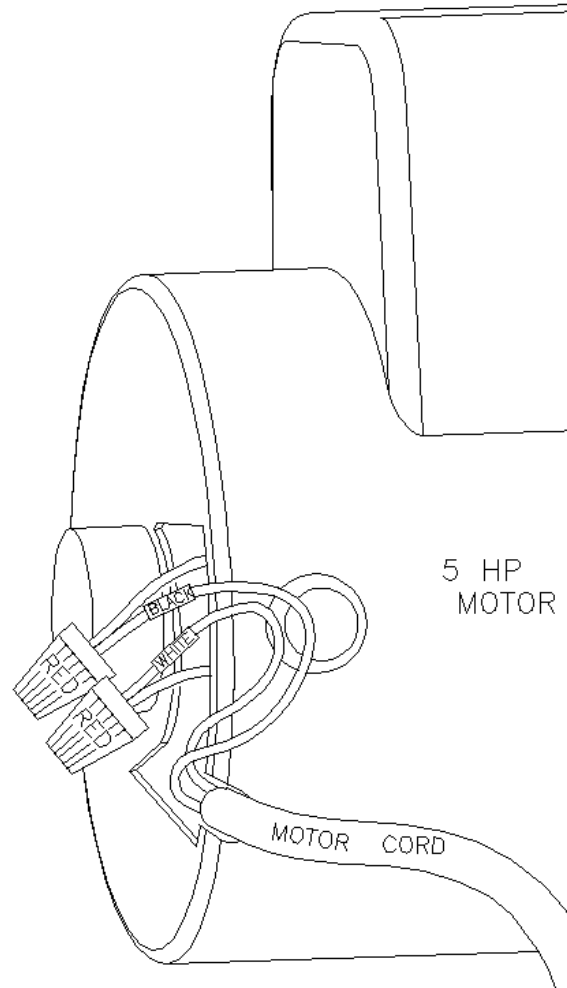

ELECTRICAL SCHEMATIC

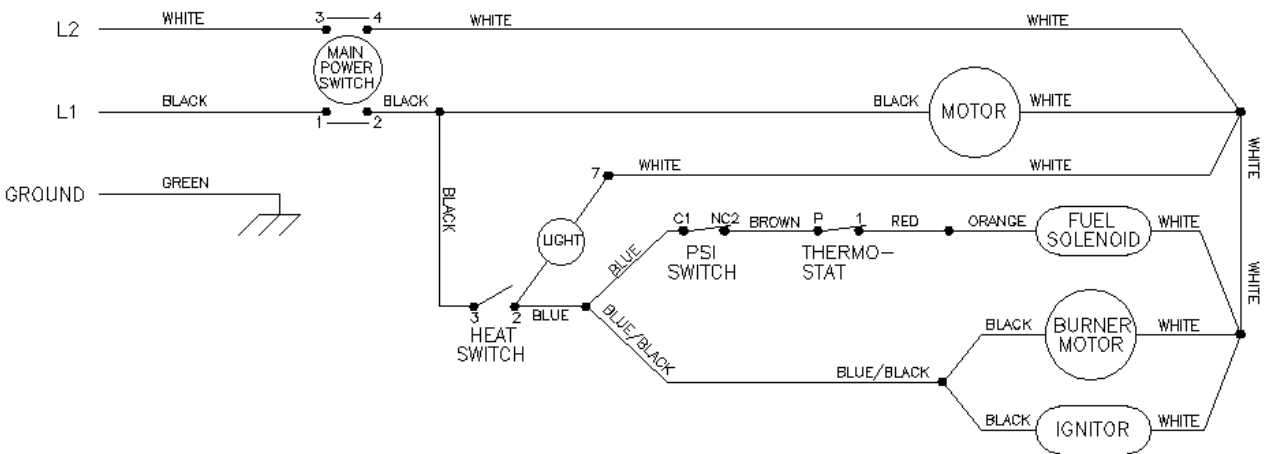

fig02197